

**Front Suspension:**

Camber: -1 °  
Total Toe: \_\_\_\_\_ °  
Ride Height: \_\_\_\_\_  
Arm Type: \_\_\_\_\_  
Tower Type: \_\_\_\_\_  
Caster Block Insert: 25 °  
Kick-Up Angle: 0 °  
Wheel Hex: \_\_\_\_\_

Notes: \_\_\_\_\_

Bump Steer Spacing:

Steering Stop Spacing:

Caster Block Spacing:

Trailing Axle Insert:

2mm  3mm  4mm

Axle Height:

Up   
Middle   
Down

Ball Stud Spacing:

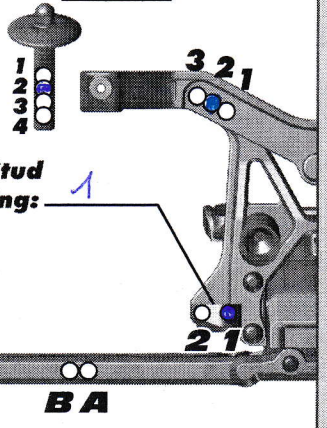

**Rear Suspension:**

Camber: -1 °  
Ride Height: \_\_\_\_\_  
Wheel Hex: \_\_\_\_\_  
Hub Spacing: Forward  Middle  Back

Notes: le + haut possible

Anti Roll Bar:

None   
Green (1.2mm)   
White (1.3mm)   
Blue (1.4mm)

Rear Hub Link Setting:

A  B  Up  Down   
B  A  Up  Down

Arm Mount:



Inboard Toe: std °  
Anti-Squat: std °  
Insert (D): \_\_\_\_\_ °

Hub Insert:

0°  0.5°  1°

Ball Stud Spacing:

+2mm  -2mm

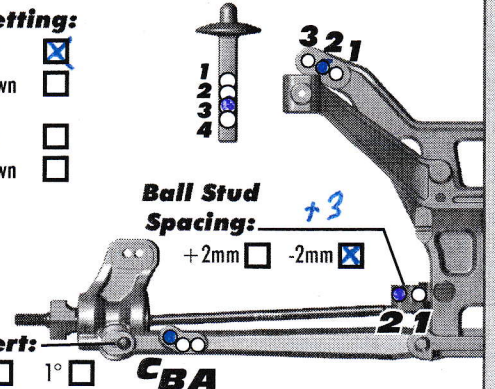

**Electronics:**

Radio: MT-4 Servo: ERG-V2  
EPA: Throttle: \_\_\_\_\_ % Brake: \_\_\_\_\_ %  
ESC: IRP FLOW  
ESC Settings: \_\_\_\_\_  
Motor: Reedy 8.0  
Wind: \_\_\_\_\_ Timing: \_\_\_\_\_  
Pinion: 23 Spur: 86  
Battery: Saddy  
Battery Position: Arrive

**Drivetrain:**

Differential:  
3 Gear:  4 Gear:   
Ball Diff:  Gear Diff:   
Notes: Plaqueux pannes  
Slipper Clutch:  
Type: std  
# of Pads: 3  
Notes: /

**Shocks:**

	Front	Rear
Piston:	<u>1,6</u>	<u>1,7</u>
Oil:	<u>3,5</u>	<u>2,5</u>
Spring:	<u>blanc</u>	<u>vert</u>
Limiters:	<u>std</u>	<u>std</u>
Cup Offset:	<u>5</u>	<u>5</u>
Stroke:		
Free Length:		
Notes:		

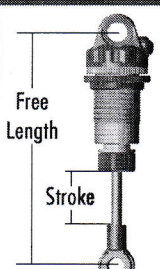

**Track Info:**

Size: Small  Medium  Large  Extra Large   
Surfaces: Dirt  Carpet  Astroturf  Multi Surface   
Traction: Low  Medium  High  Very High   
Moisture: Dry  Damp  Wet   
Condition: Indoor  Outdoor  Dusty  Hard Packed   
Bumpy  Grooved  Smooth  Loamy   
Temperature: Ambient: 15° Track: \_\_\_\_\_  
Notes: \_\_\_\_\_

**Tires:**

Tires (F/R): JC CARVERS / JC BARE CODE  
Compound (F/R): blanc / BLEU (soft)  
Insert (F/R): Mousse / Mousse  
Wheel (F/R): AVID / AVID  
Notes: TRAITEMENT WD 40

**Body & Wing:**

Body: SC5M  
Wing: /  
Notes: /

**Race Results:**

Qualify: 3-0-3 Main: 5-8-9  
Finish: (8-7) TQ:   
Best Lap Time: \_\_\_\_\_

**Vehicle Comments:**

Plaque 62 gr sous saddle + 40 gr sur pare-choc AR + 2 plaques de plomb derrière le pack  
Total Vehicle Weight: \_\_\_\_\_